

Absolute Local Positioning System

Eurobot 2012



Prof. Michael Ansorge
Prof. Wolfram Luithardt

Michaël
Defferrard

Table des matières

- Bref rappel du cahier des charges
- Concept
- Signaux et traitements
- Implémentation matérielle et logicielle
- Conclusion

Eurobot 2012

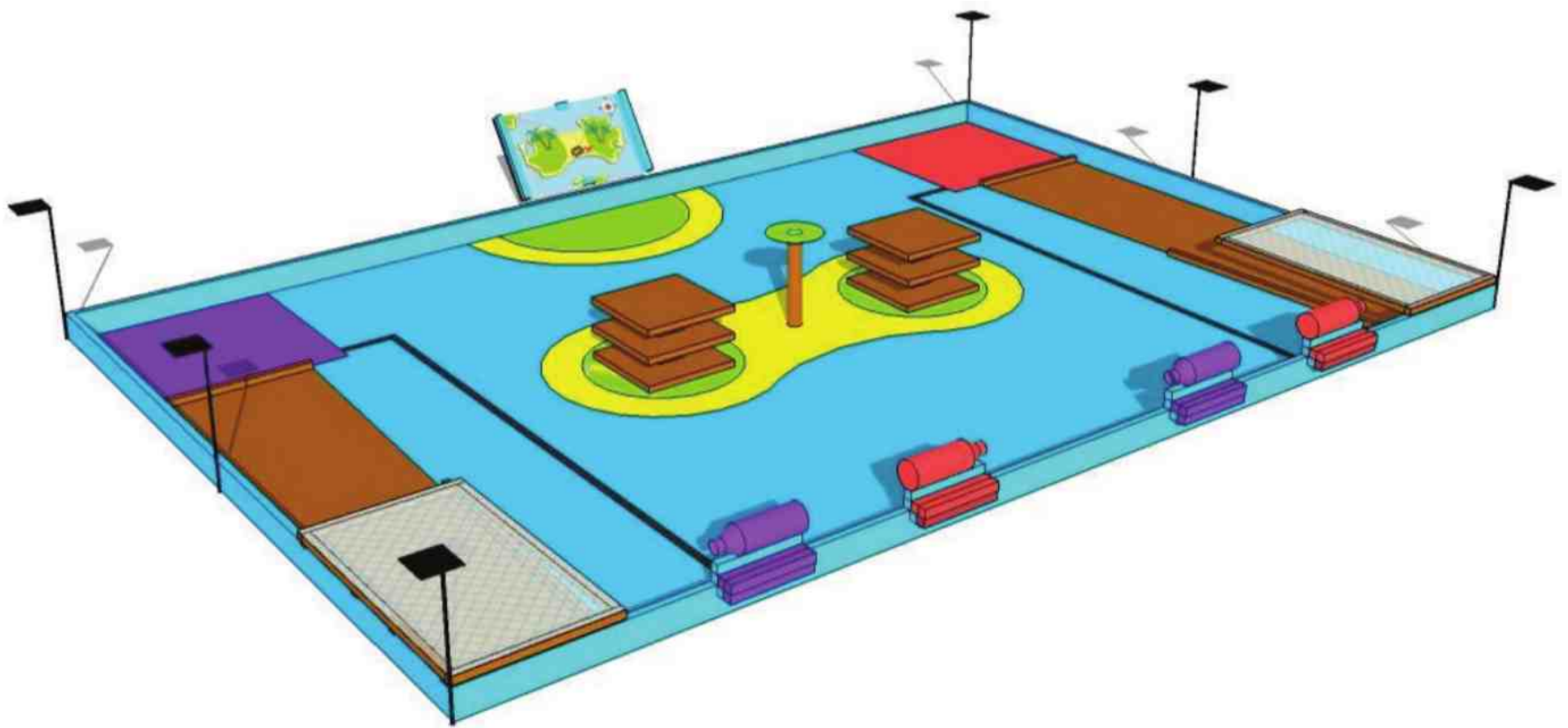

Positionnement

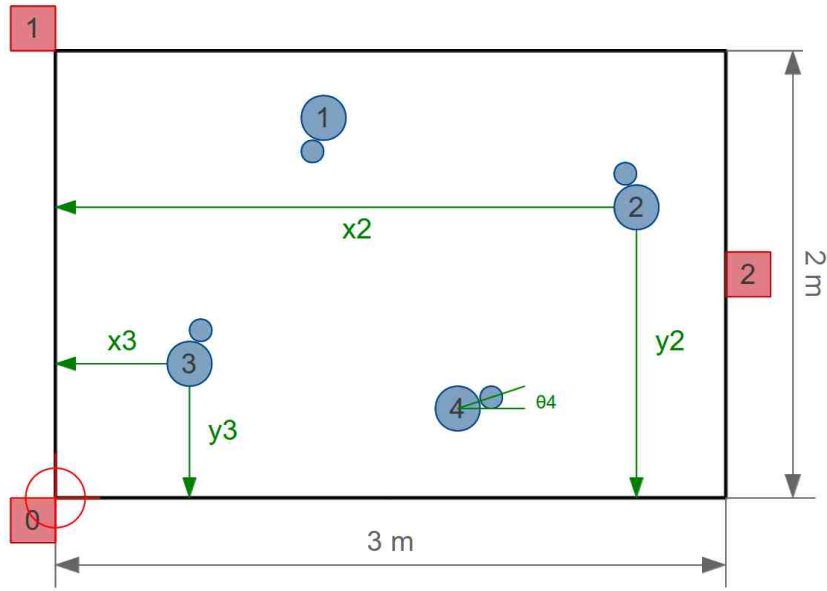

 balise  robot

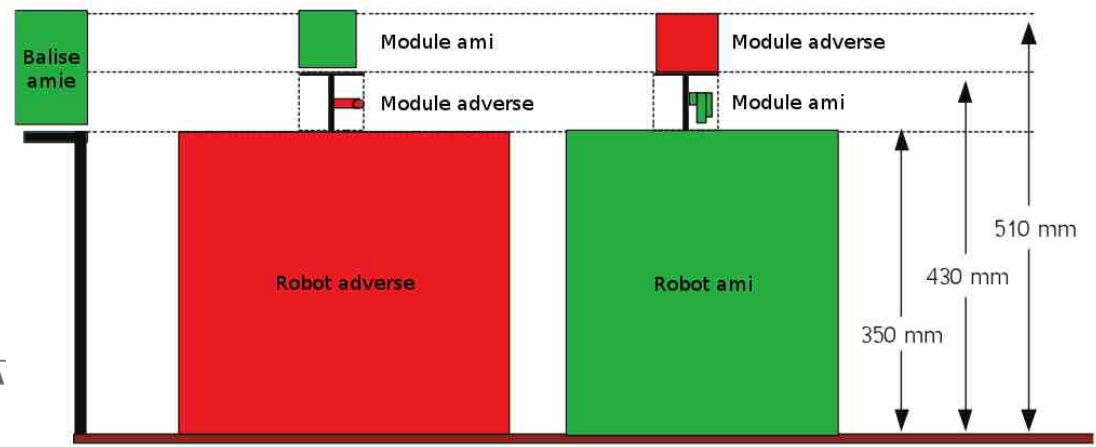

Concept

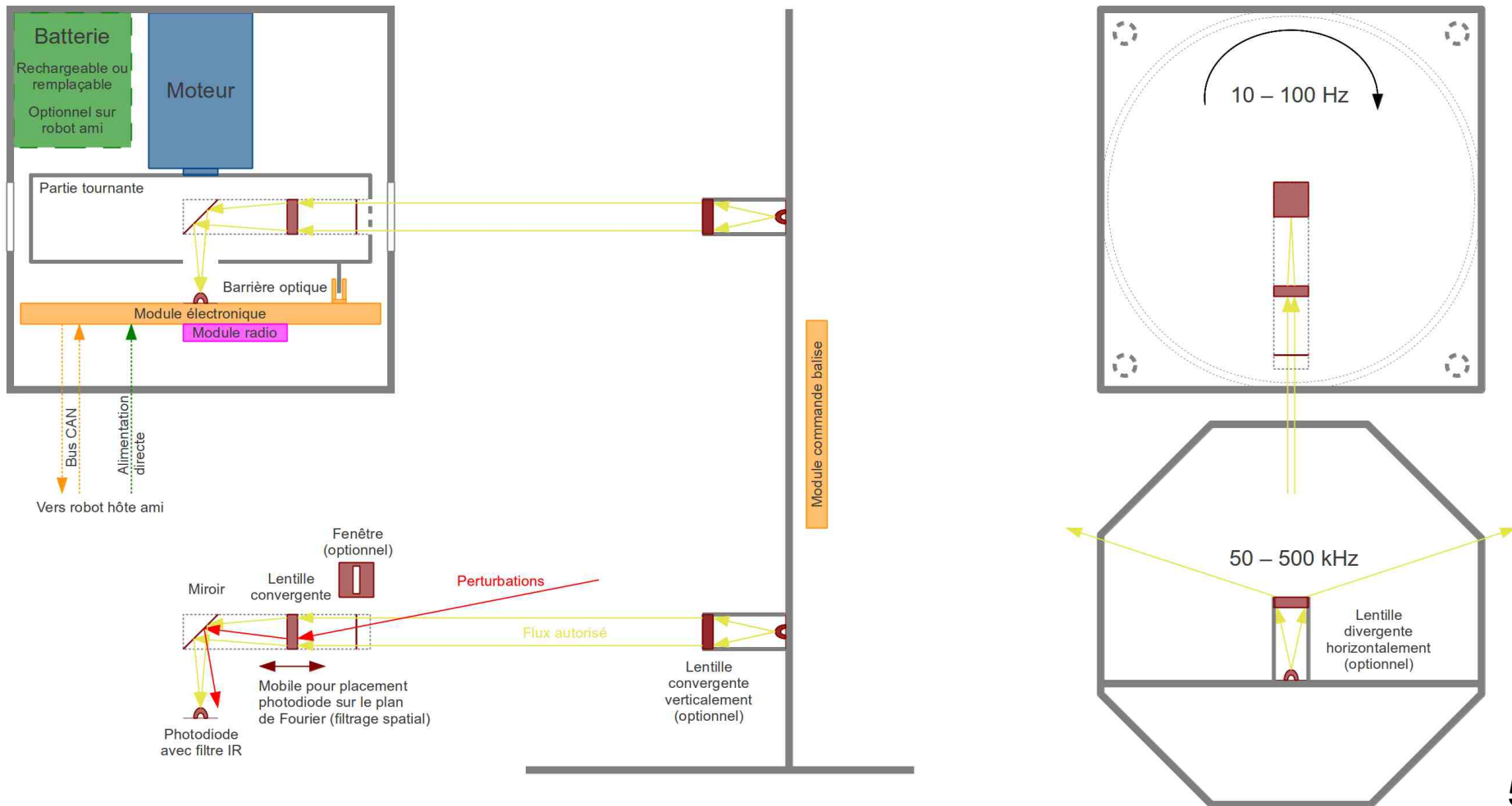

Concept

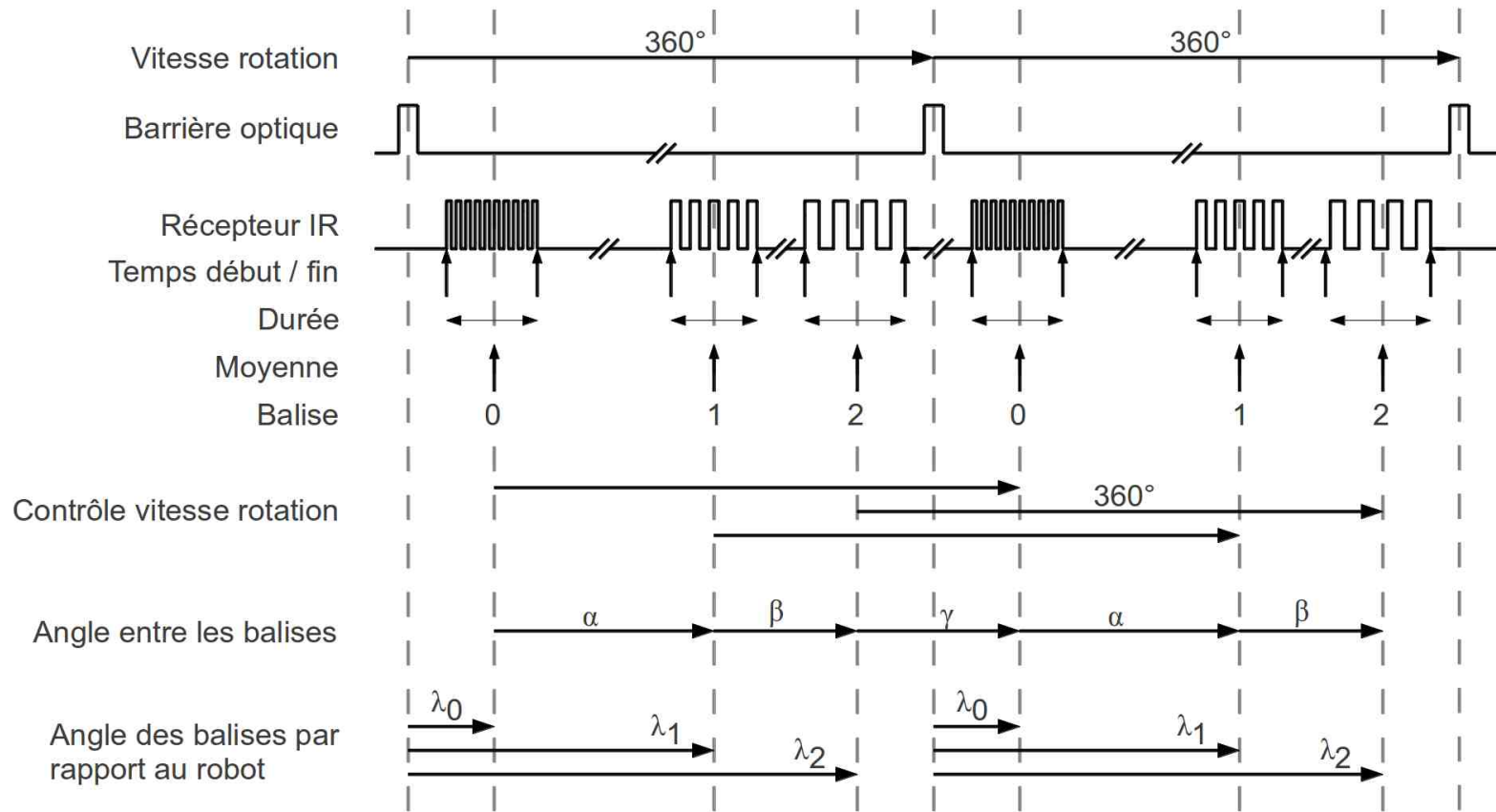

Concept

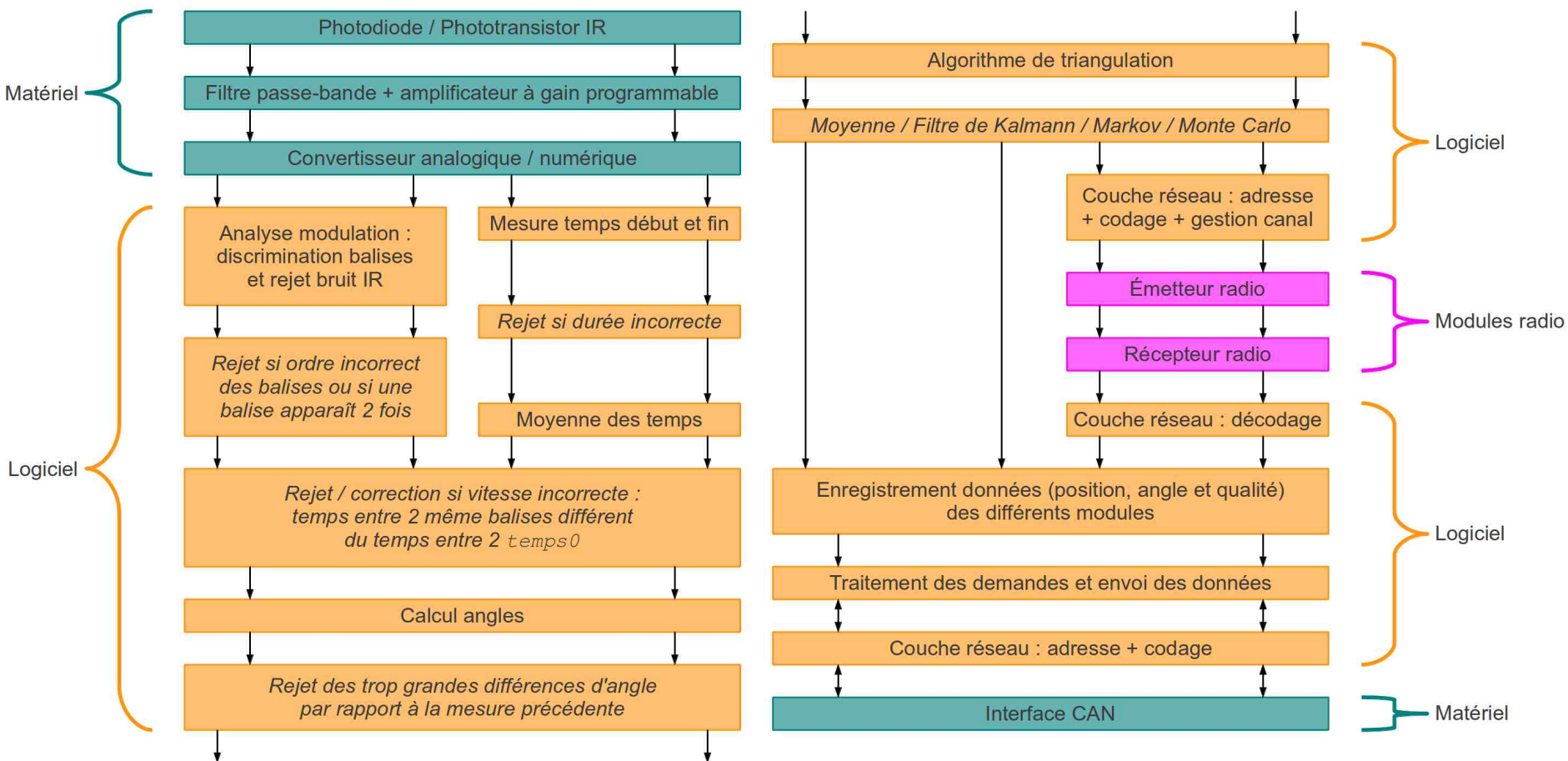

Signaux

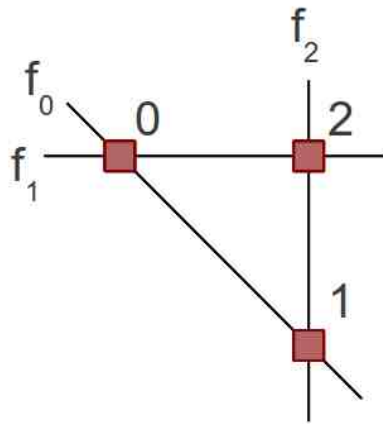

DTMF
Dual Tone Frequency Modulation

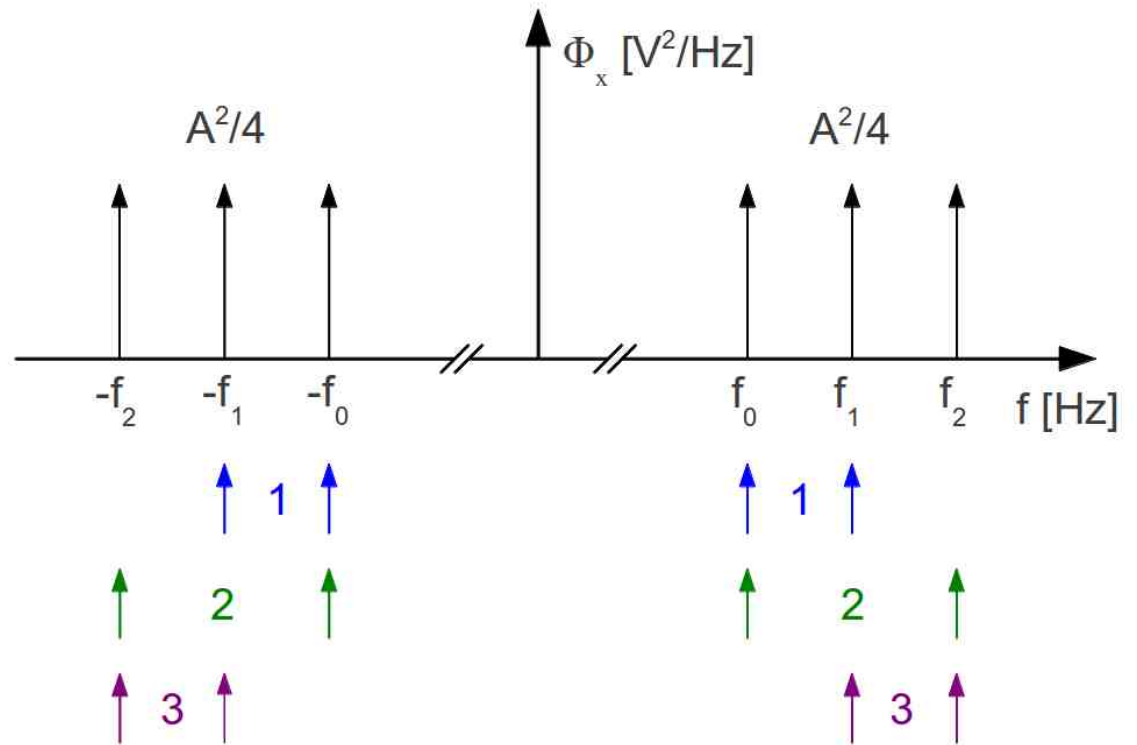

Traitement du signal

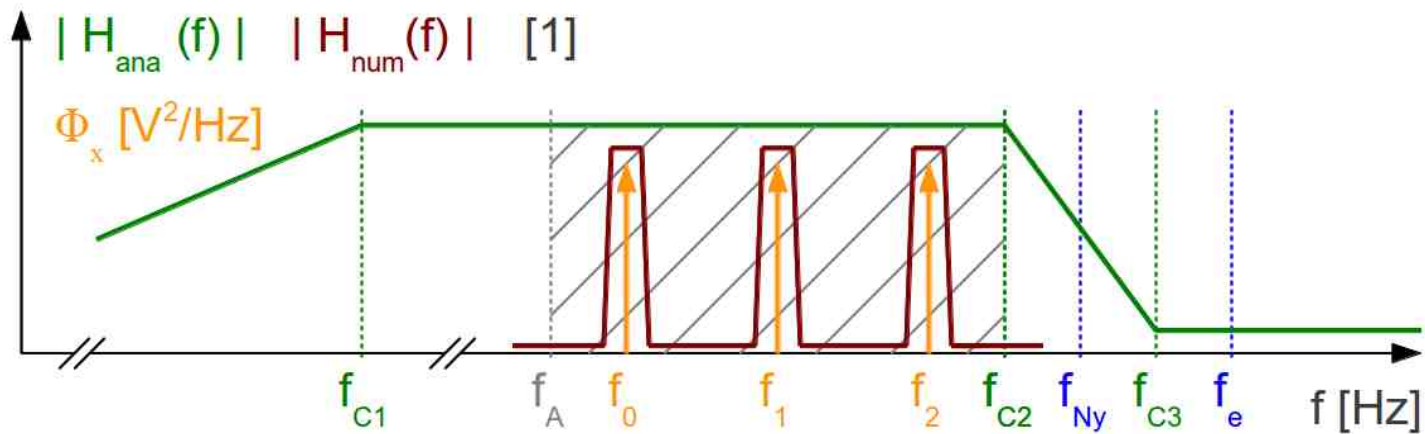
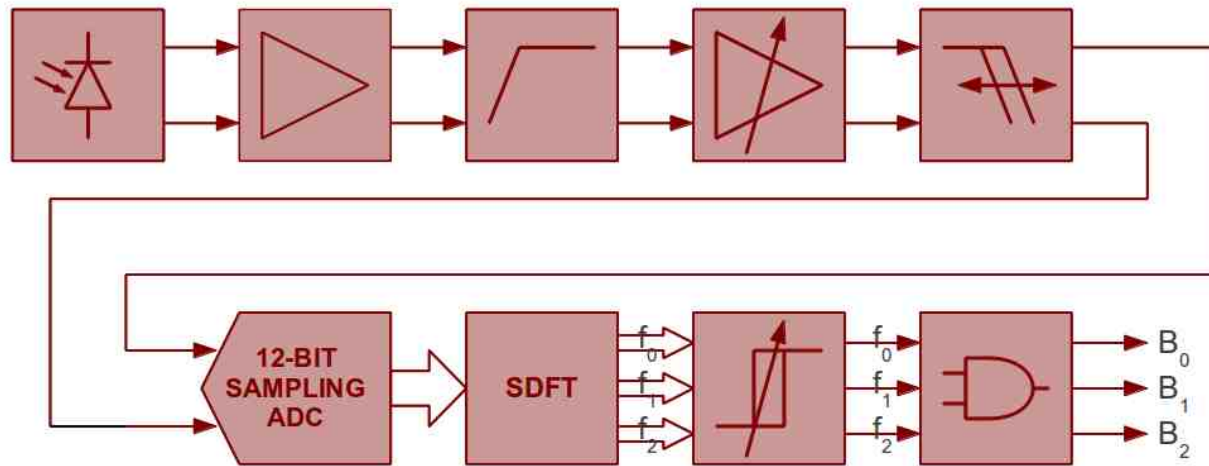

Simulations numériques

Time plot, $f_e=500\text{kHz}$, $N=280$ samples

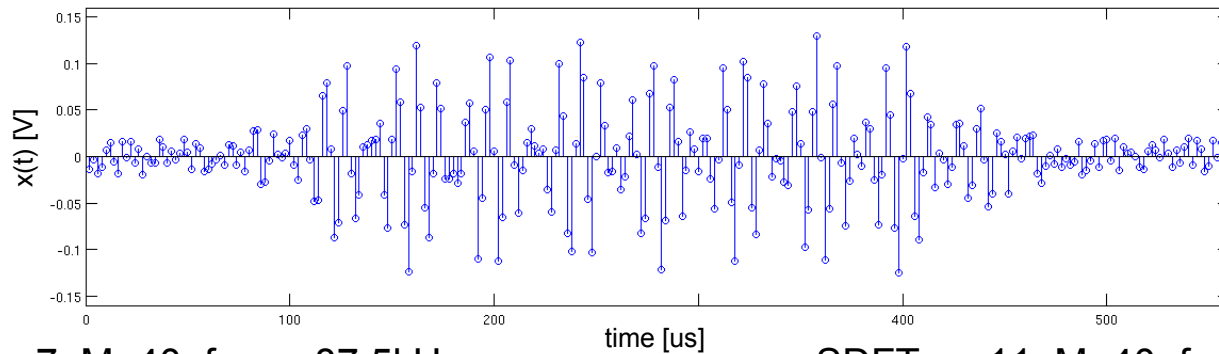

SDFT $m=7$, $M=40$, $f_{mes}=87.5\text{kHz}$

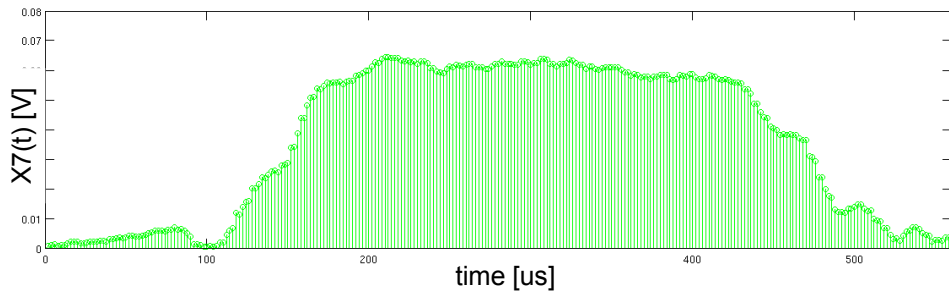

SDFT $m=11$, $M=40$, $f_{mes}=137.5\text{kHz}$

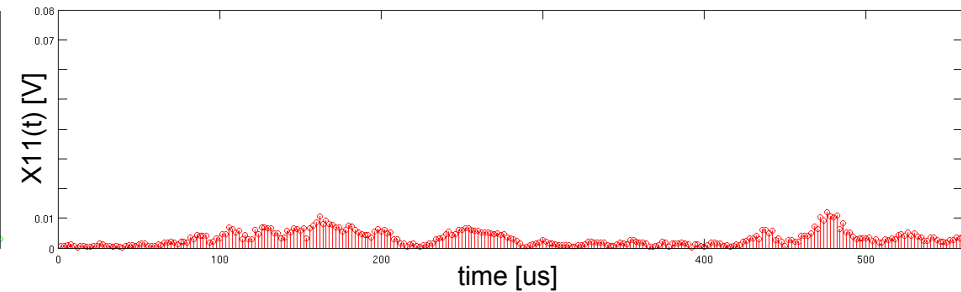

SDFT $m=9$, $M=40$, $f_{mes}=112.5\text{kHz}$

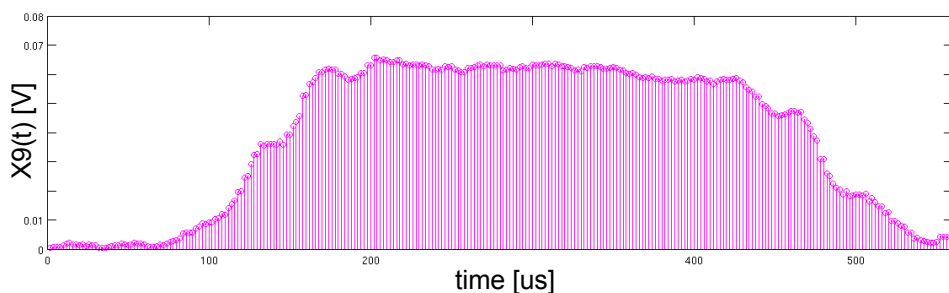

Traitement analogique

Photodiode IR
VR = 1.65 V

Amplificateur à transconductance
G = 50 kohm

Filtre passe-haut
Butterworth 2ème ordre
Gain = 2, $f_c = 1.6$ kHz

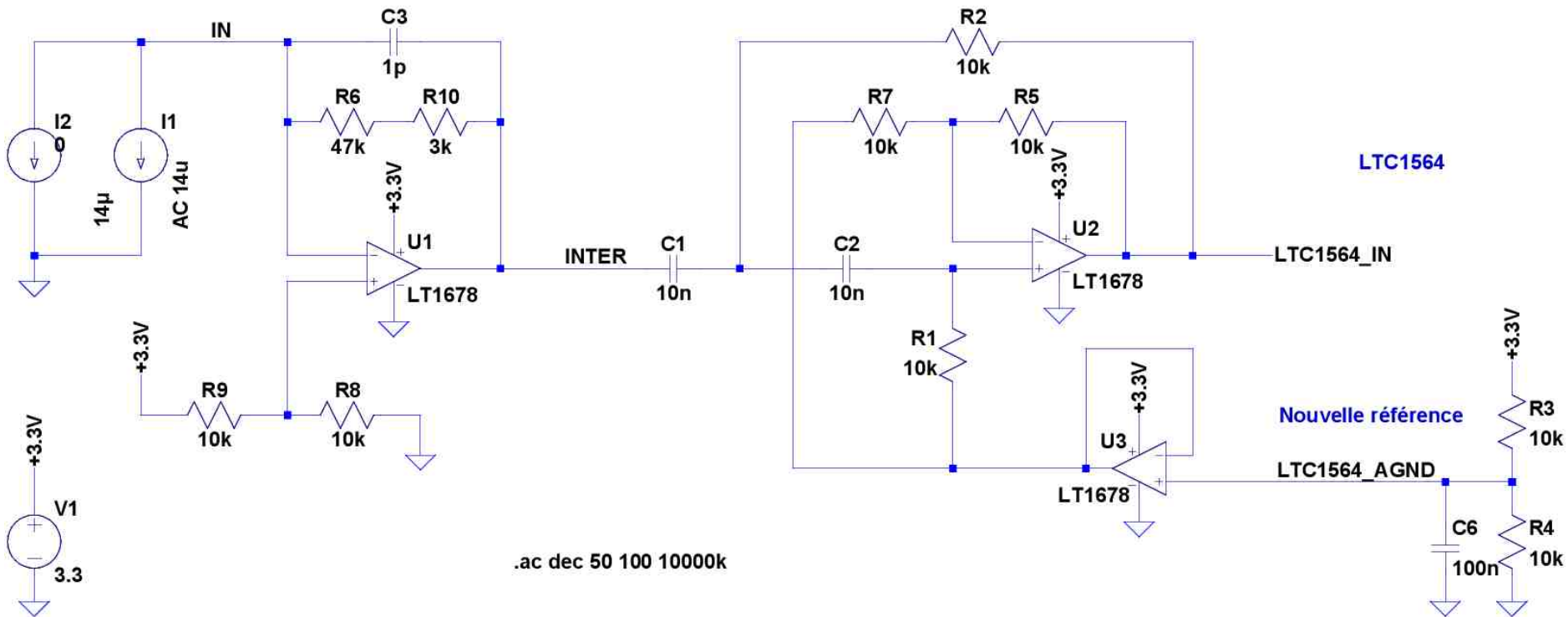

Traitement numérique

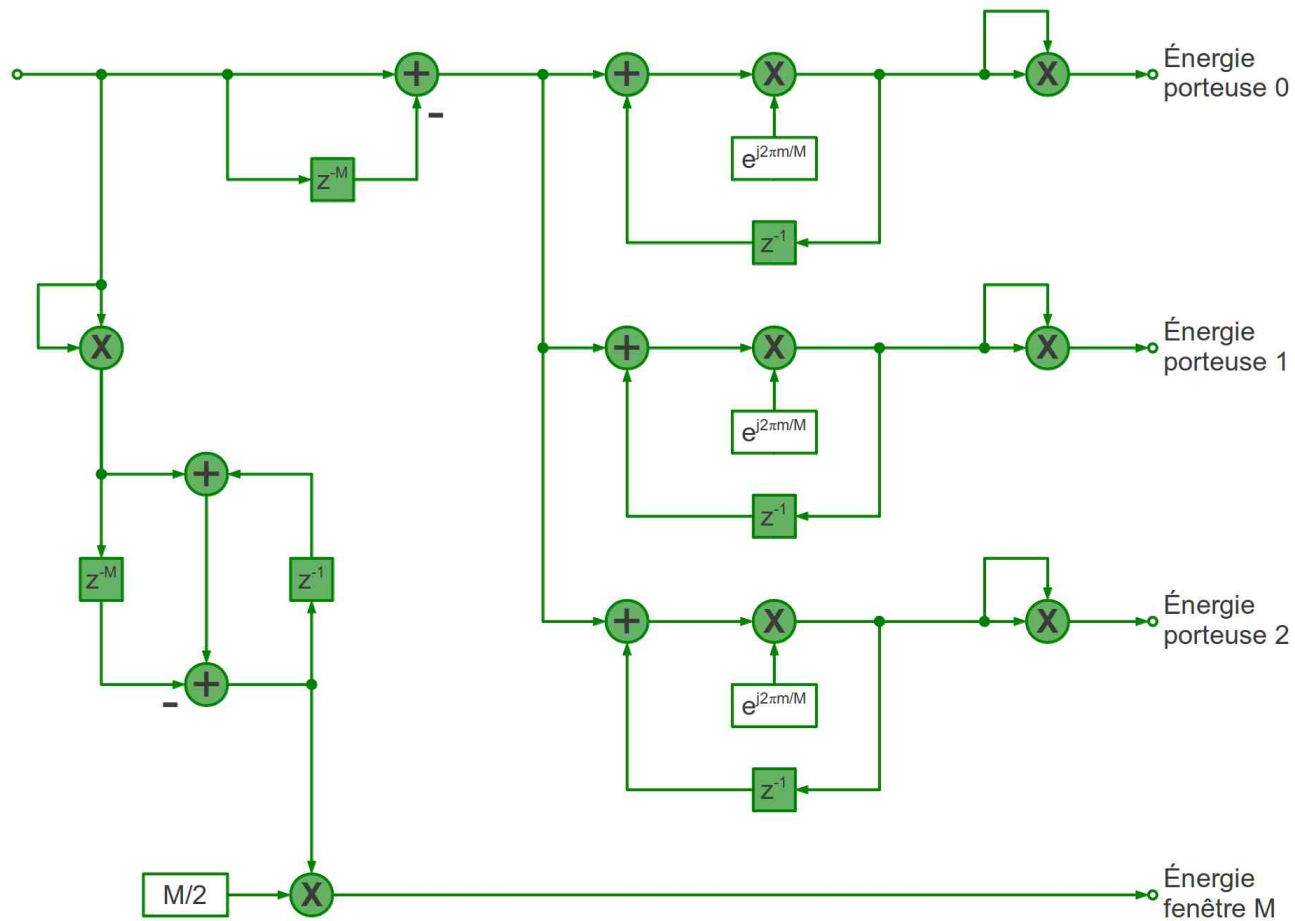

Électronique module

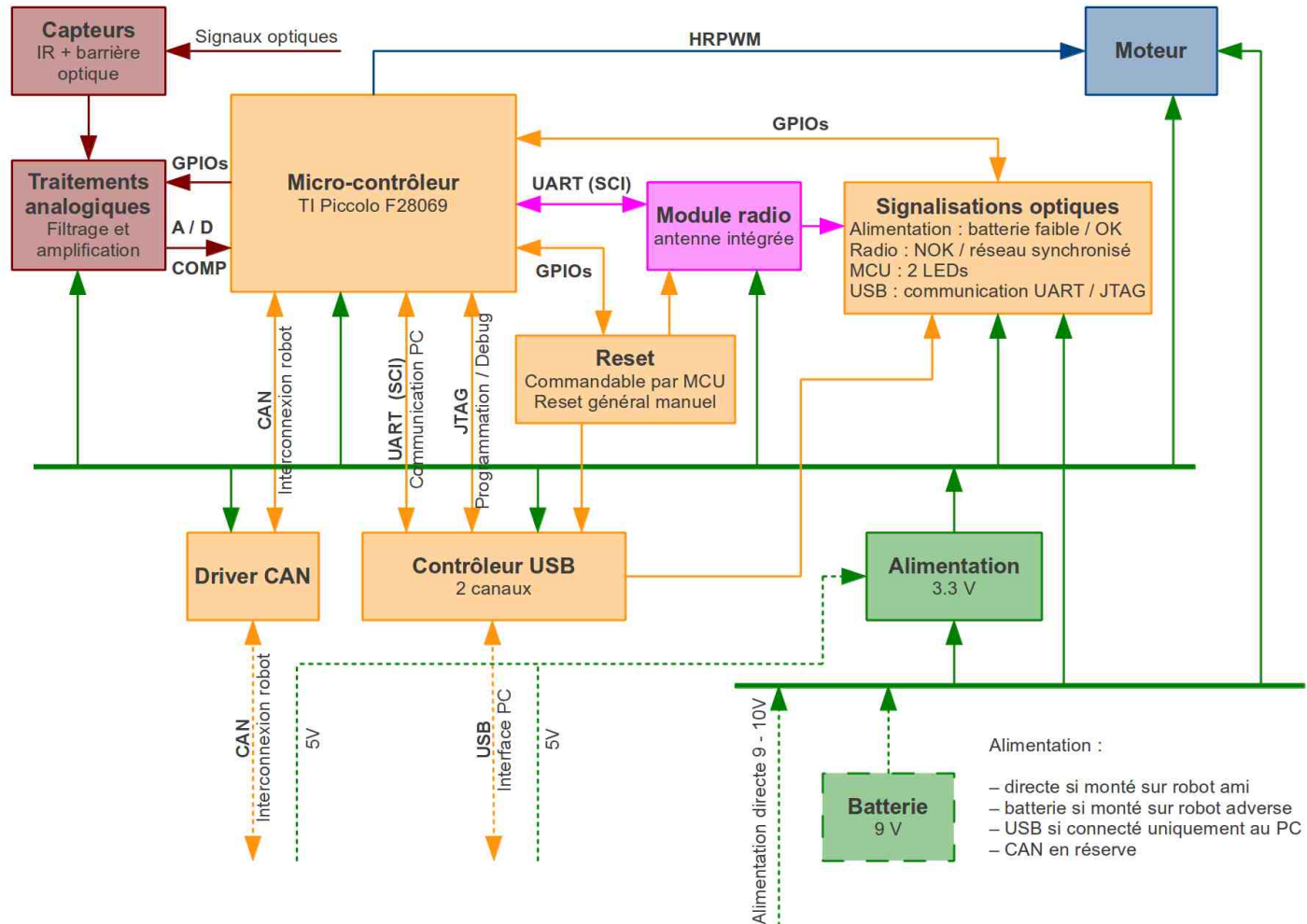

Architecture logicielle

Mémoire CPU

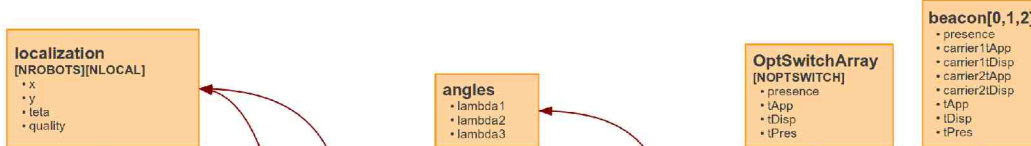

Mémoire partagée



Mémoire CLA

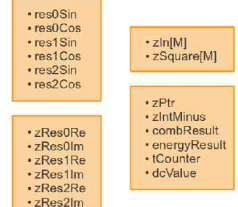

CPU

Programmé en C

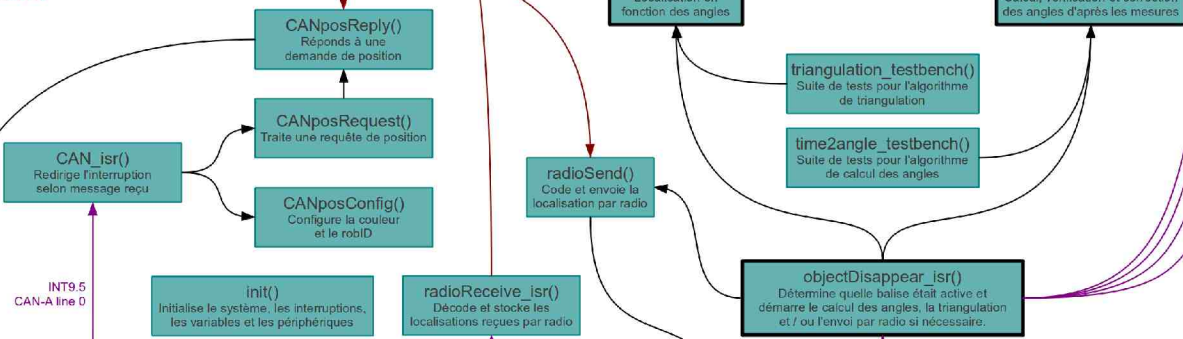

CLA

Programmé en ASM

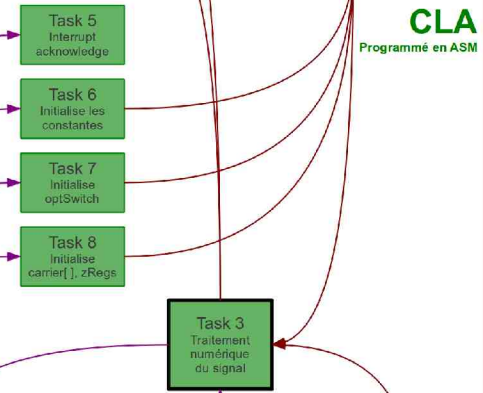

Périphériques



Conclusion

